



Features:

- Universal AC input 85~264VAC
- Protections: Short circuit / Overload / Over voltage
- Can be installed on DIN rail TS-35/7.5 or 15
- The body width is only 35mm
- No load consumption<0.5W
- Isolation class II
- LED indicator for power on
- High reliability
- 3 years warranty
- Compliance to IEC/EN/UL 62368-1

Specification

MODEL		SIP45-5	SIP45-12	SIP45-24	SIP45-48
INPUT	VOLTAGE RANGE	85~264VAC 120~370VDC (Refer to "Static characteristics")			
	FREQUENCY RANGE	47~63Hz			
	EFFICIENCY(Typ.)	82%	88%	90%	91%
	AC CURRENT(Typ.)	1.1A/115VAC 0.6A/230VAC			
	INRUSH CURRENT(Typ.)	25A/115VAC 45A/230VAC (cold start)			
OUTPUT	DC VOLTAGE	5V	12V	24V	48V
	RATED CURRENT	4A	2.5A	1.87A	0.94A
	CURRENT RANGE	0~4A	0~2.5A	0~1.87A	0~0.94A
	RATED POWER	20W	30W	44.88W	45.12W
	RIPPLE&NOISE (max.)	80mVp-p	100mVp-p	100mVp-p	100mVp-p
	VOLTAGE ADJ.RANGE	5~5.5V	10.8~13.8V	21.6~28.8V	43.2~57.6V
	VOLTAGE TOLERANCE	±2%	±1%	±1%	±1%
	LINE REGULATION	±1%	±0.5%	±0.5%	±0.5%
	LOAD REGULATION	±2%	±1%	±1%	±1%
	SETUP, RISE TIME	500ms,50ms/230VAC 500ms,50ms/115VAC			
	HOLD UP TIME(Typ.)	30ms/230VAC 7ms/115VAC			
PROTECTION	OVER LOAD	105%~160% rated output power Protection type: hiccup mode, recovers automatically after fault condition removed			
	OVER VOLTAGE	6.2~8V	15~18V	30~36V	60~66V
		Protection type: Shunt down, recovers after repower on			
ENVIRONMENT	WORKING TEMP.,HUMIDITY	-30~+70°C (Refer to "Derating curve") , 20~90%RH non-condensing			
	STORAGE TEMP.,HUMIDITY	-40~+85°C, 10~95%RH			
	TEMP. COEFFICIENT	±0.03%/°C (0~50°C)			
	VIBRATION	10~500Hz, 2G 10min./1 cycle, each along X、Y、Z axes			

Safety and electromagnetic compatibility	Safety standards	Refer to UL62368-1,TUV EN62368-1,CCC GB4943.1		
	Withstand voltage and isolation resistance	I/P-O/P: 4KVac ; 100MΩ / 500Vdc / 25°C / 70%RH		
	Electromagnetic	Parameter	Standard	Test Level / Note
		Conducted emission	BS EN/EN55032(CISPR32),FCC PART 15 / CISPR22 ,GB9254.1	Class B
		Radiated emission	BS EN/EN55032(CISPR32),FCC PART 15 / CISPR22 ,GB9254.1	Class B
		Harmonic current	BS EN/EN61000-3-2,GB17625.1	Class A
		Voltage flicker	BS EN/EN61000-3-3	----
		BS EN/EN55035		
		Parameter	Standard	Test Level /Note
		ESD	BS EN/EN61000-4-2	Level 4, 8KV air, Level 2, 4KV contact, criteria A
Electromagnetic compatibility immunity		RF field susceptibility	BS EN/EN61000-4-3	Level 3, criteria A
		EFT bursts	BS EN/EN61000-4-4	Level 3, criteria A
		Surge susceptibility	BS EN/EN61000-4-5	Level 4, 2KV/L-N criteria A
		Conducted susceptibility	BS EN/EN61000-4-6	Level 3, criteria A
		Magnetic field immunity	BS EN/EN61000-4-8	Level 4, criteria A
		Voltage dips and interruptions	BS EN/EN61000-4-11	>95% dip 0.5 periods, 30% dip 25 periods , >95% interruptions 250 periods
OTHERS	MTBF	≥1000Khrs MIL-HDBK-217F(25°C)		
	DIMENSION	35*90*54.5mm(W*H*D)		
	PACKING	0.15Kg; 84pcs/ 13.6Kg/ 1.1CUFT		
NOTE	<p>1. All parameters NOT specially mentioned are measured at 230VAC input, rated load and 25°C of ambient temperature.</p> <p>2. Ripple & noise are measured at 20MHz of bandwidth by using a 12" twisted pair-wire terminated with a 0.1uF & 47uF parallel capacitor.</p> <p>3. Tolerance: includes set up tolerance, line regulation and load regulation.</p> <p>4. Line regulation is measured from low line to high line at rated load.</p> <p>5. Load regulation is measured from 0% to 100% rated load</p> <p>6. Length of set up time is measured at cold first start, Turning ON/OFF the power supply very quickly may lead to increase of the set up time.</p> <p>7. The ambient temperature derating of 5°C/1000m is needed for operating altitude great than 2000m(6500ft).</p> <p>8. The power supply is considered a component which will be installed into a final equipment. All the EMC tests are been executed by mounting the unit on a 360mm*360mm metal plate with 1mm of thickness. The final equipment must be re-confirmed that it still meets EMC directives.</p> <p>9. Installation clearances:40mm on top,20mm on the bottom,5mm on the left and right side are recommended when loaded permanently with full power. In case the adjacent device is a heat source, 15mm clearance is recommended.</p>			

Mechanical specification

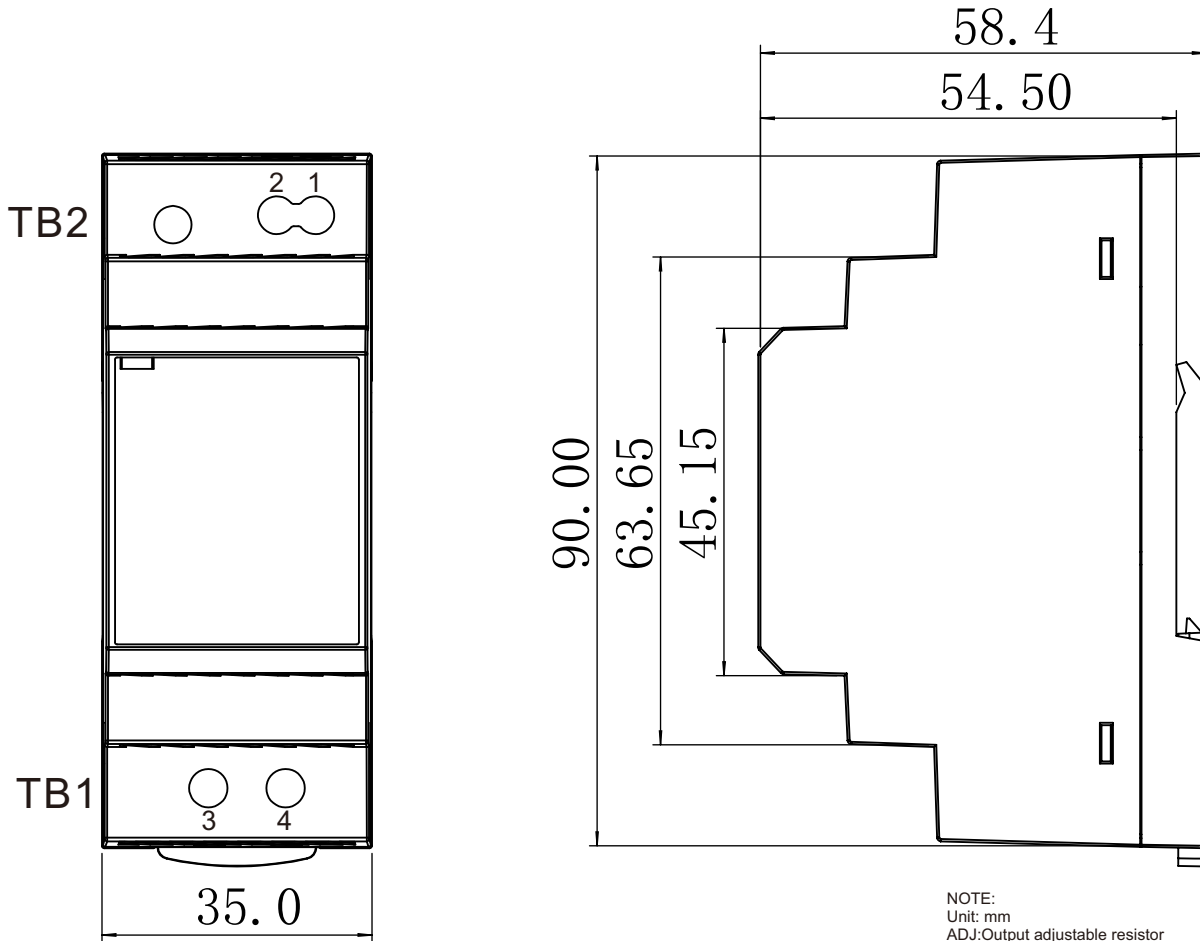

NOTE:
Unit: mm
ADJ: Output adjustable resistor
TOL: ±1.00

ADMISSIBLE DIN-RAIL: TS35/7.5 OR TS35/15
Terminal Pin No. Assignment

TB1		TB2	
Pin No.	Assignment	Pin No.	Assignment
3	AC/N	2	DC output -V
4	AC/L	1	DC output +V

Block diagram

